

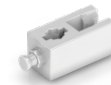

















Bill of materials

-  x17
-  x10
-  x23
-  x32
-  x20

-  x4
-  x20
-  x10
-  x10
-  x30
-  x10
-  x1
-  x1
-  x1
-  x1
-  x1
-  x1
-  x1



- 1** model printed instructions (included) 
- 2** models online 3D instructions 

Engineo

Engineo

3 IN 1

MODELS

WHEELED LOADER

CREATIVE BUILDER



© Copyright Engineo-Net Limited. All Rights Reserved

Terms & Conditions: All ENGINEO® Resources, including but not limited to parts, electronics, software, theory, activities and building instructions, either in digital or physical format, is protected by patents and copyrights. License is granted only for Private use. Any Commercial use is strictly prohibited, including but not limited to education centers. By using ENGINEO® Resources you accept our Terms and Conditions of use. If you need license for commercial use, email to iplicense@engineo.com



EU OFFICE & FACTORY:
 ENGINEO-NET LIMITED
 P.O.BOX 72100, 4200
 LIMASSOL, CYPRUS
 Tel.: +357 25821960
 Fax: +357 25821961
 E-mail: info@engineo.com
 Web: www.engineo.com



WARNING:
 CHOKING HAZARD—Small parts.
 Not for children under 3 yrs.

Product Code:
CB-M20
 Edition 3.0

young engineers

Machinery series

- 6+** Appropriate Ages
- 3** Years Warranty
- Free 3D Viewer App
- Extraction Tool For easy disassembly of small parts

Building Tips

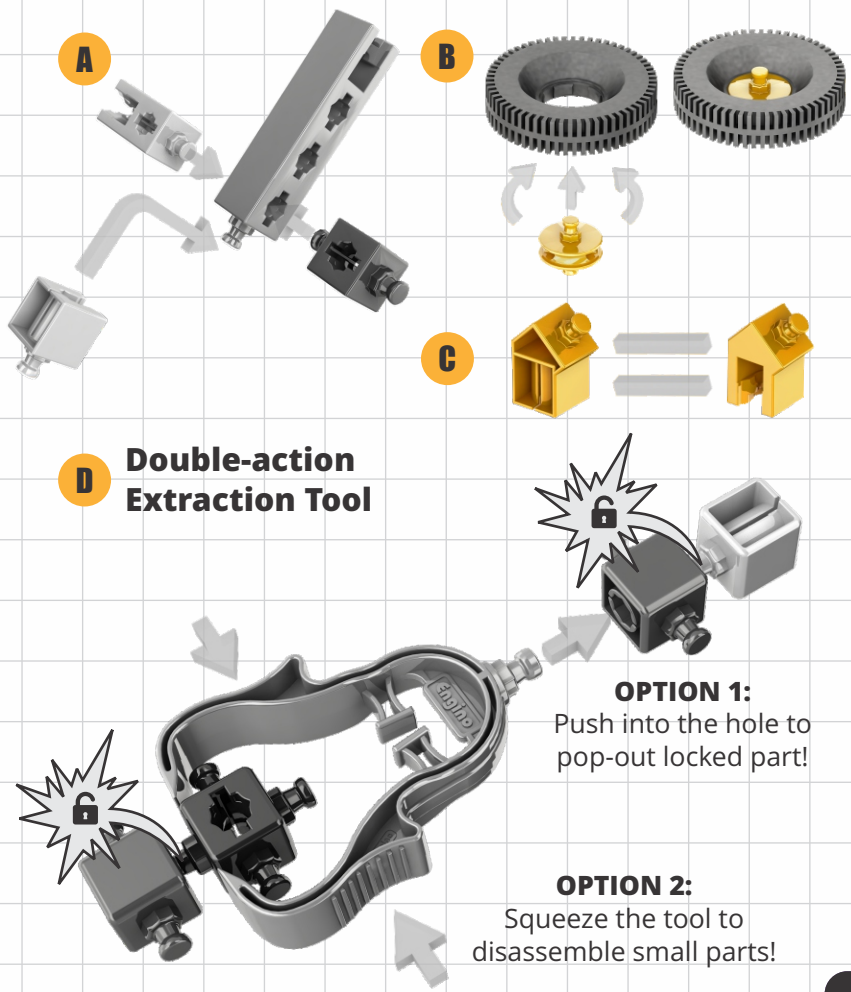

Free App

Download the app to discover step-by-step instructions in 3D view!

Engino kidCAD (3D Viewer) app:

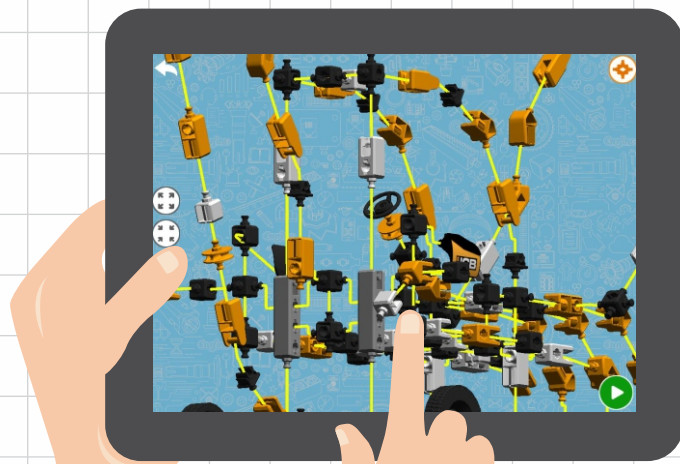

01

Building Instructions

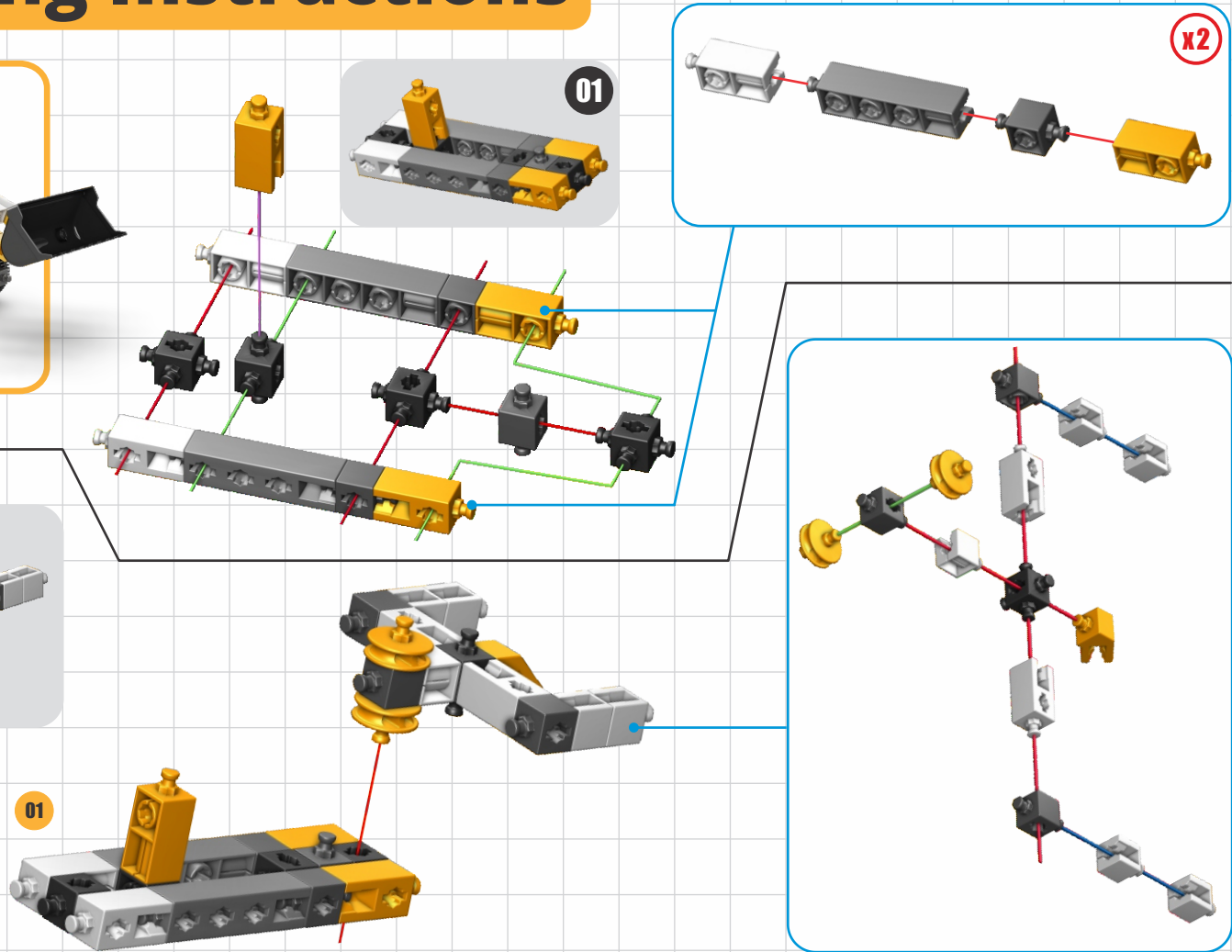
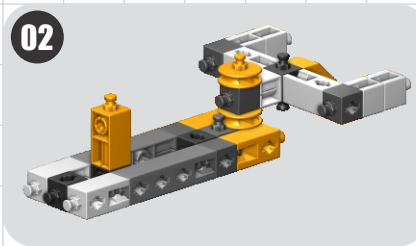

02

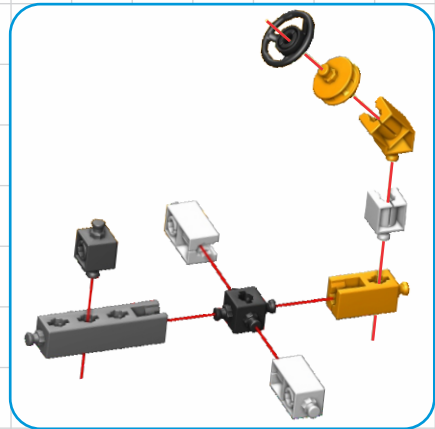

02

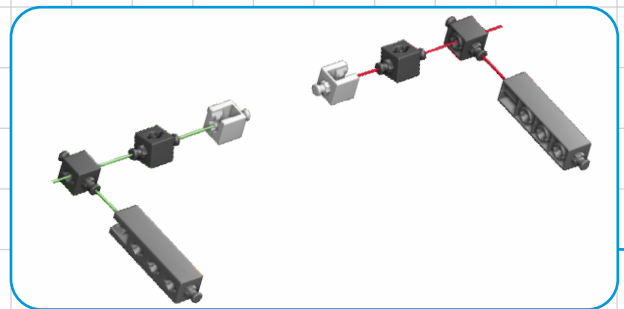
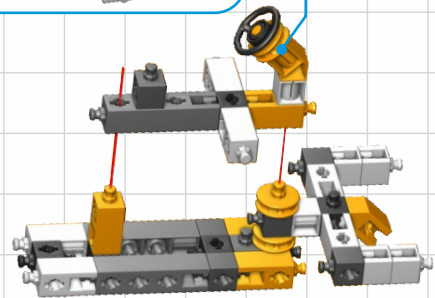

03

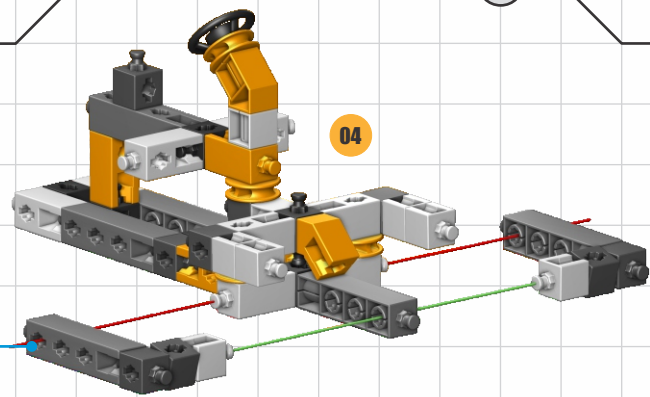

03

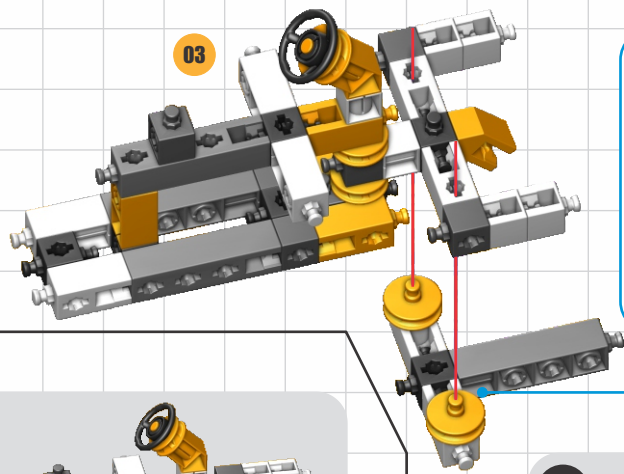
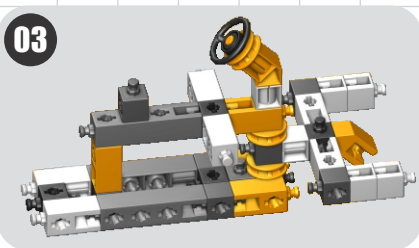

04

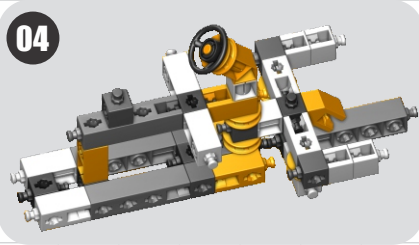

05

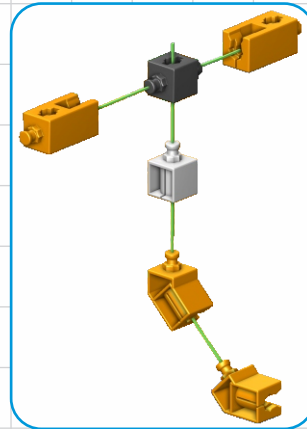
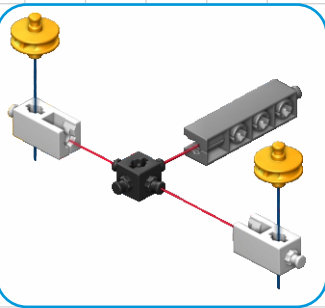
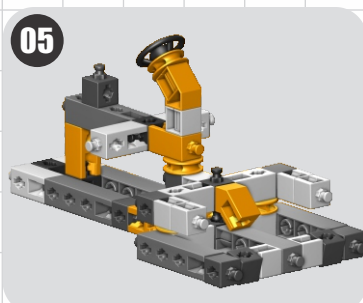

06

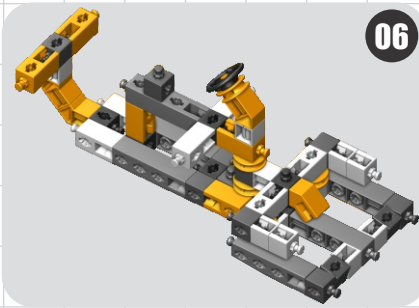

08

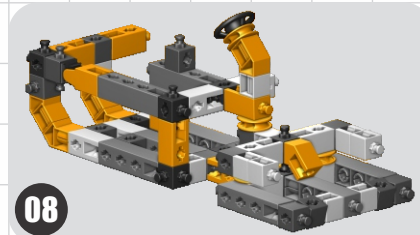

07

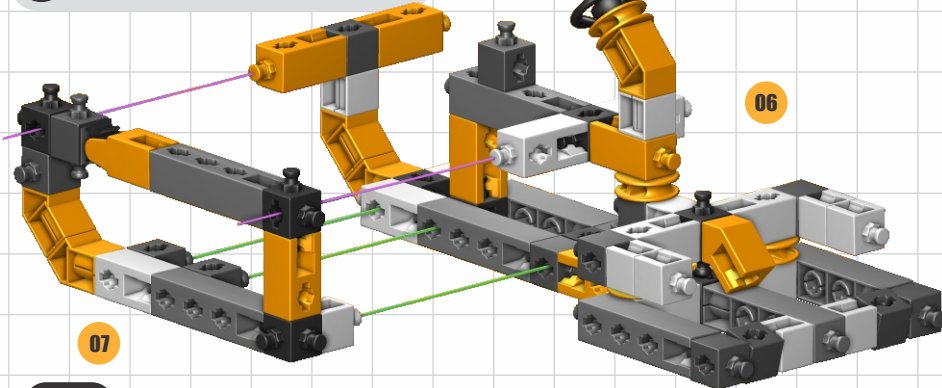

06

04

05

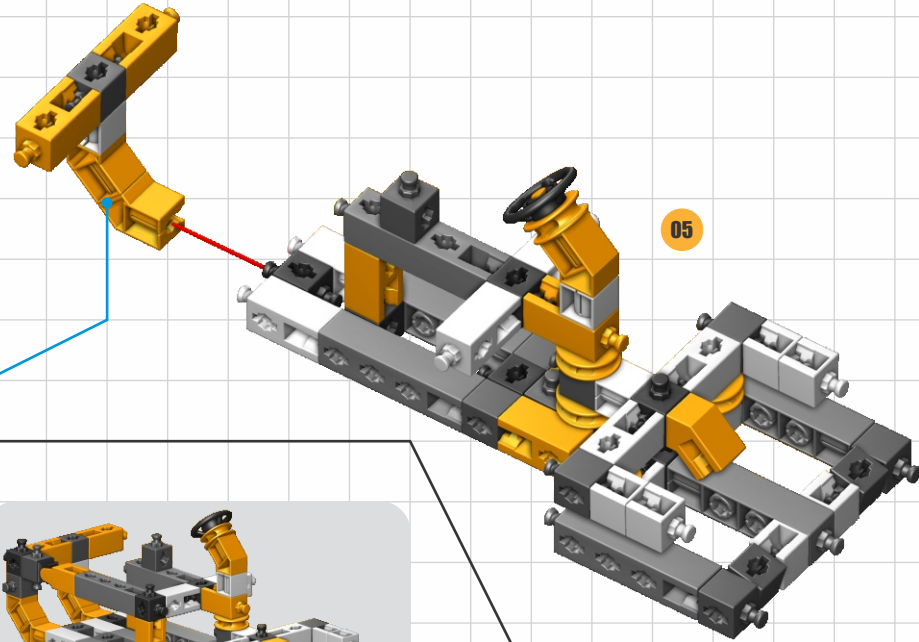

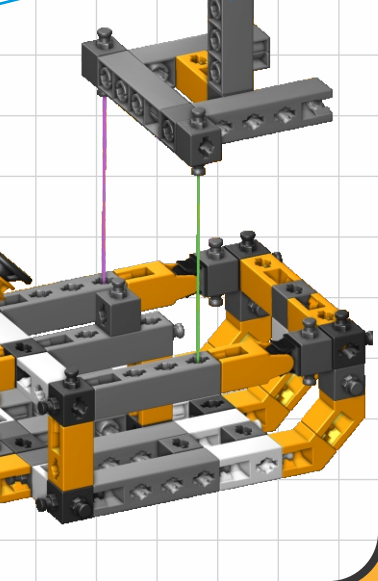
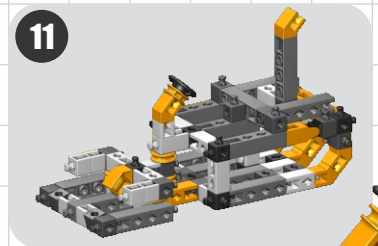
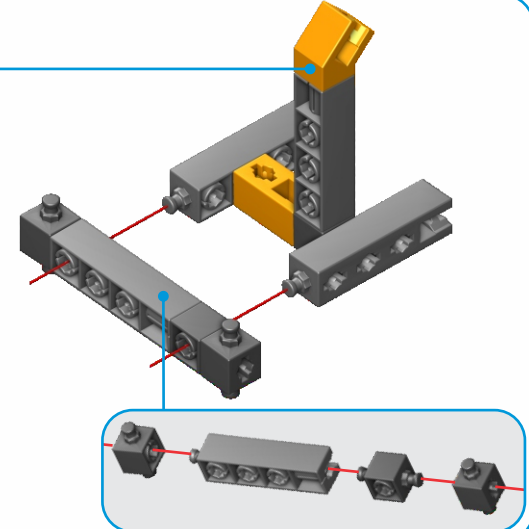
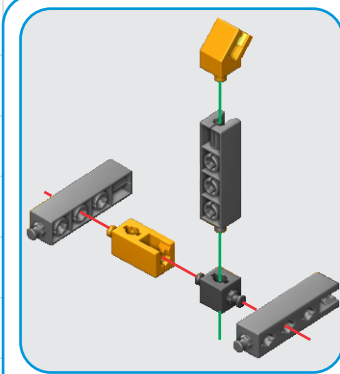
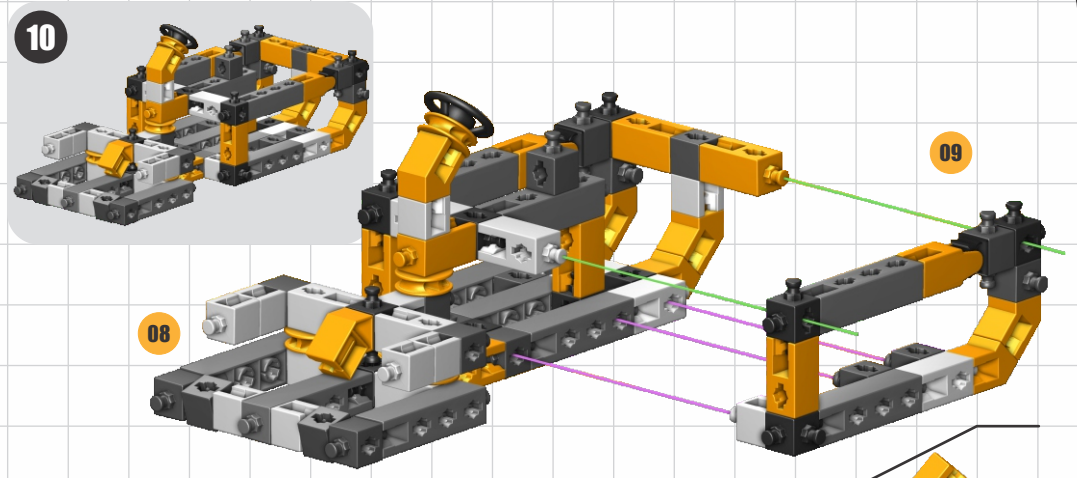
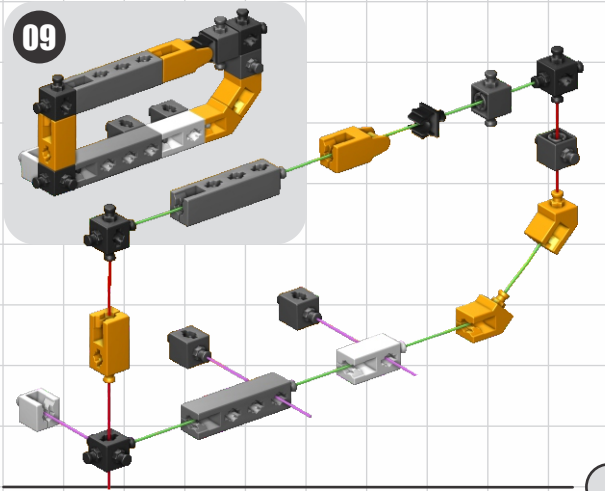

05

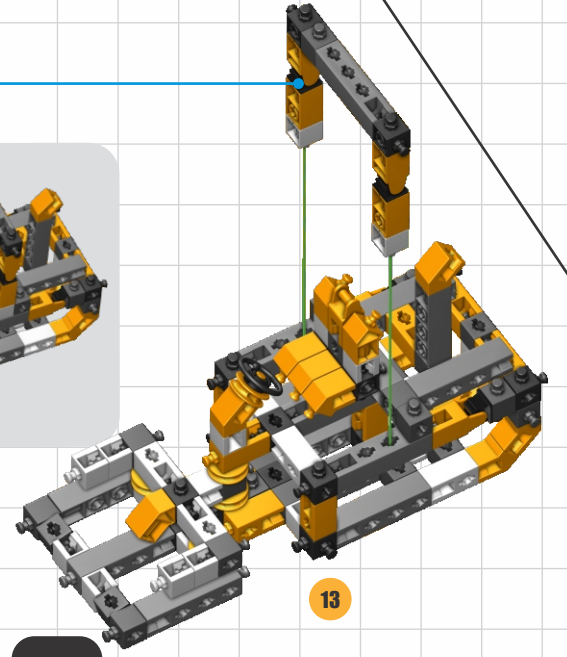
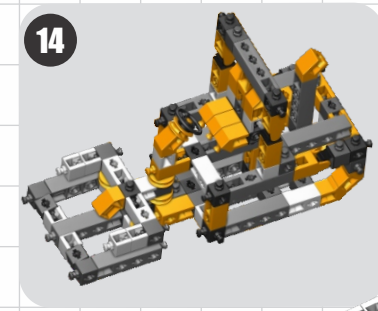
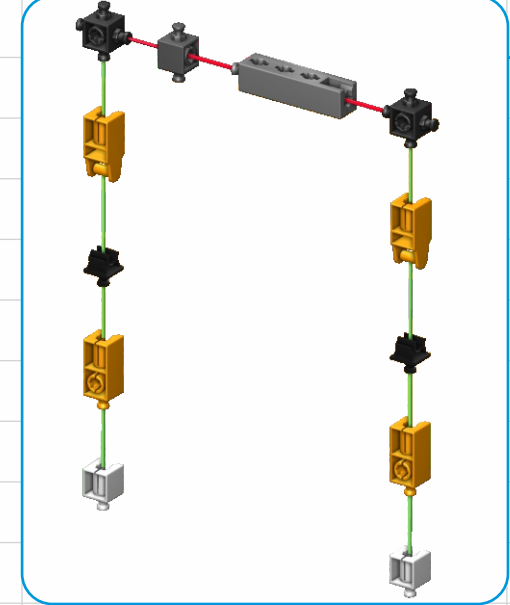
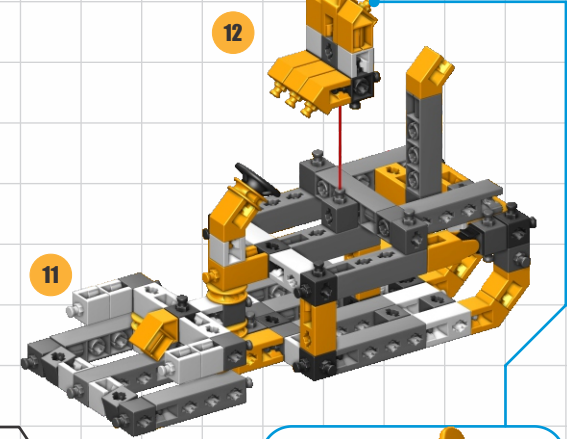
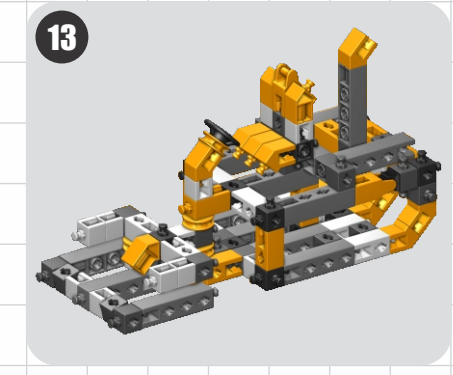
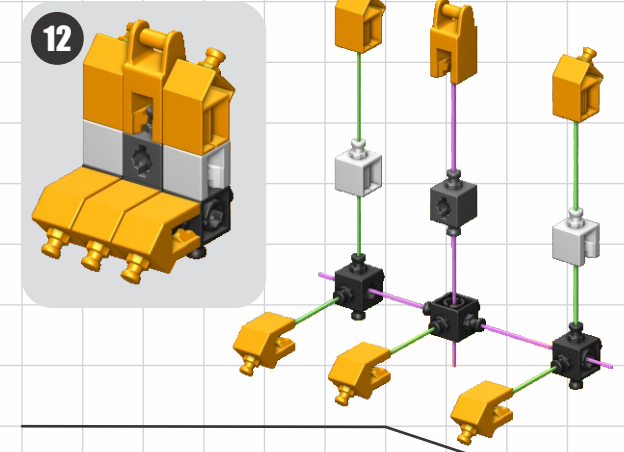

06

